

Cast Steel Bolted Bonnet Valves

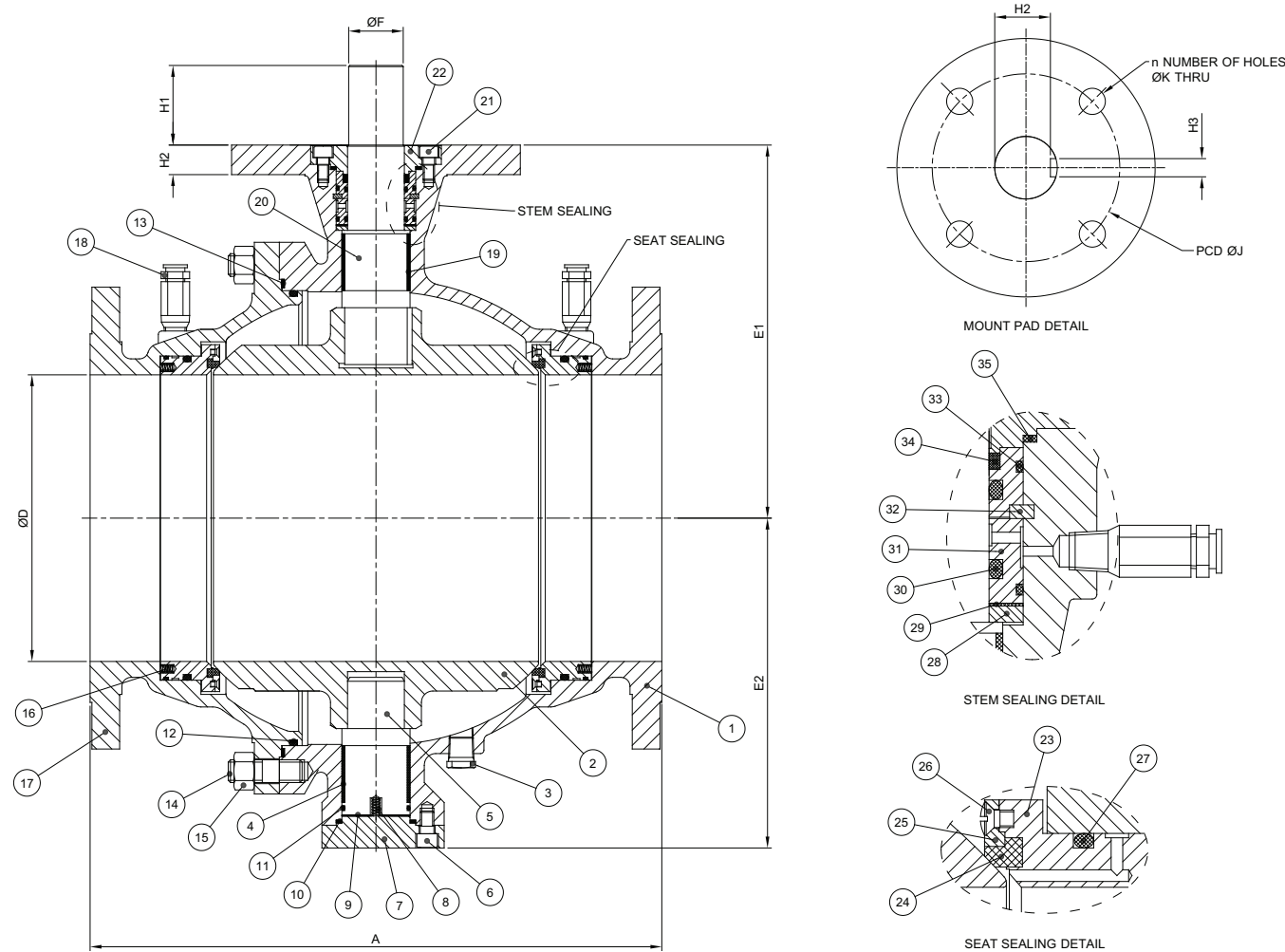

Cast Steel Trunnion Ball Valves Product Overview



Size

2" - 28" (Full Port)
Fire Safe as Standard

End Connections

150# RF Flanged
300# RF Flanged
600# RF Flanged
900# RF Flanged
1500# RF Flanged
Butt Weld

Valve Materials

304/304L/316/316L Stainless Steel
Carbon Steel
LCB, LCC Carbon Steel

Ball and Stem Materials

304/304L/316/316L Stainless Steel
Nickel Plated Carbon Steel

Seat Materials

Teflon
Nylon
PEEK
Devlon
Metal

Service Applications

Chemical
Food Processing
Oxygen
Steam
Thermal Fluids
Vacuum
Water/Oil/Gas

Applicable Standards

ASME B16.34
ASME B16.10
ASME B16.5
API 607/API 6FA
API 6D



Cast Steel Bolted Bonnet Valves

Cast Steel Trunnion Ball Valves Product Overview

Item	Description	Materials				
		Carbon Steel	Sulfur Proof	304 Stainless Steel	316 Stainless Steel	LCB, LCC
1	Body	A216-WCB	A216-WCB	A351-CF8, CF3	A351-CF8M, CF3M	A352-LCB, LCC
2	Ball	A105 + ENP	A105 + ENP	304, 304L	316, 316L	304, 316, LF2 + ENP
3	Plug	A105	A105	304, 304L	316, 316L	304, 316
4	Lower Stem Bearing	304 or 316 + PTFE				
5	Lower Stem	A182-F6a	A182-F6a	A182-F304, F304L	A182-F316, F316L	A182-F304, F316, F6a
6	Lower Cover Screw	A193-B7	A193-B7M	A193-B8/B8M	A193-B8/B8M	A350-L7
7	Lower Cover	A105	A105	A182-F304, F304L	A182-F316, F316L	LF2
8	Anti-Static Spring	304, 316, 17-7PH, X-750				
9	Thrust Bearing	304 or 316 + PTFE				
10	Lower Cover Gasket	304 or 316 + Graphite Spiral Wound				
11	Lower Stem Seal	Viton, HNBR				
12	Body Seal	Viton, HNBR				
13	Body Gasket	304 or 316 + Graphite Spiral Wound				
14	Body Stud	A193-B7	A193-B7M	A193-B8/B8M	A193-B8/B8M	A350-L7
15	Body Bolt	A194-2H	A194-2HM	A194-8/8M	A194-8/8M	A194-7
16	Seat Spring	304, 316, 17-7PH, X-750				
17	End Cap	A216-WCB	A216-WCB	A351-CF8, CF3	A351-CF8M, CF3M	A352-LCB, LCC
18	Sealant Injector	A105 + Zn	A105 + Zn	304, 304L	316, 316L	304, 316
19	Upper Stem Bearing	304 or 316 + PTFE				
20	Upper Stem	A182-F6a	A182-F6a	A182-F304, F304L	A182-F316, F316L	A182-F304, F316, F6a
21	Gland Screw	A193-B7	A193-B7M	A193-B8/B8M	A193-B8/B8M	A350-L7
22	Packing Gland	A105 + Zn	A105 + Zn	A182-F304, F304L	A182-F316, F316L	A182-F304, F316, F6a
23	Seat Ring	A105 + ENP	A105 + ENP	A182-F304, F304L	A182-F316, F316L	304, 316, LF2 + ENP
24	Seat	RPTFE, Nylon, PEEK, Devlon, Metal				
25	Seat Retainer	A105 + ENP	A105 + ENP	A182-F304, F304L	A182-F316, F316L	A182-F304, F316, F6a
26	Seat Retainer Screw	A193-B7	A193-B7M	A193-B8/B8M	A193-B8/B8M	
27	Seat Ring Seal	Viton, HNBR				
28	Thrust Ring	A105 + Zn	A105 + Zn	A182-F304, F304L	A182-F316, F316L	A182-F304, F316, F6a
29	Thrust Bearing	304 or 316 + PTFE				
30	Inner Stem Seal	Viton, HNBR				
31	Sealing Ring	A105 + Zn	A105 + Zn	A182-F304, F304L	A182-F316, F316L	A182-F304, F316, F6a
32	Anti-Blowout Ring	A105 + Zn	A105 + Zn	A182-F304, F304L	A182-F316, F316L	A182-F304, F316, F6a
33	Outer Stem Seal	Viton, HNBR				
34	Packing	Graphite				
35	Gland Gasket	304 or 316 + Graphite Spiral Wound				

Notes Regarding Dimensional Tables

- All dimensions in the above tables are for guidance only and can be subject to change dependant upon actual operating conditions and design parameters specified at point of sale. Accurate drawings are available for each valve size and can be supplied once an order is placed.
- The torque values are based upon opening torque for soft seated valves at maximum differential pressure and clean gas or liquid conditions. No safety factor has been applied.
- Metal seated versions have a torque approximately three times higher than that shown in the tables.
- All mount pads conform to ISO 5211.

Bi-directional Upstream Sealing

This valve is equipped with two spring energized seats which provide pre-loading and thereby effective sealing at low pressures. Sealing is enhanced at higher pressures as the upstream pressure creates a piston effect on the seat. Both seats are identical thus ensuring true bi-directional operation.

Anti-Static Design

A number of metal components are isolated by packing and bearing materials which can cause electrical conductance continuity to be lost. To overcome this, spring energized balls are installed to maintain continuity and prevent the possibility of sparking resulting from static.

Emergency Sealant System

Valve sizes 6" and above (smaller sizes upon request where design allows) are fitted with an injection system. This system enables the user to inject special sealing grease around the stem seals and seats to create an emergency temporary seal in the event of a fire or seal/seat failure.

Blow-Out Prevention Stem

The stem has an integral shoulder as part of the design to prevent blow-out if excess pressure is encountered during operation.

Fire-Safe Design

In the event of a fire, several safety features are in place to prevent leakage. The seats have a metal lip that is pushed against the ball after the main seat melts away to effect temporary sealing. The main external joints have spiral wound gaskets to withstand the high temperatures encountered during a fire.

Seat Design Variations

These valves are supplied with self relieving (single piston) seat designs as standard. These seats also act as double block and bleed when the ball is in the closed position via the vent or drain port. Double piston effect seat design is available upon request and is suggested to be used in conjunction with a body cavity relief valve.

ANSI Class 150 Dimensions

SIZE	A (mm)		D (mm)	E (mm)	F (mm)	H1 (mm)	H2 (mm)	H3 (mm)	J (mm)	K (mm)	n	ISO 5211	Weight (kg)	TORQUE (N.m)	CV
	RF Flanged	Butt Weld													
2"	178	216	49	115	20	35	16.5	6	102	11	4	F10	12	42	500
2 1/2"	191	241	62	128	24	40	20	8	102	11	4	F10	16	65	1050
3"	203	283	74	135	24	40	20	8	125	14	4	F12	22	100	1300
4"	229	305	100	175	32	45	24	10	125	14	4	F12	35	165	2300
6"	394	457	150	242	42	60	37	12	165	23	4	F16	74	380	5400
8"	457	521	201	290	48	65	42.5	14	165	23	4	F16	205	640	10000
10"	533	559	252	328	48	65	42.5	14	165	23	4	F16	280	1150	17800
12"	610	635	303	375	55	70	49	16	165	23	4	F16	355	1650	26000
14"	686	762	335	405	60	75	53	18	254	19	8	F25	576	2650	32000
16"	762	838	385	460	75	95	67.5	20	254	19	8	F25	864	3350	44000
18"	864	914	436	498	75	95	67.5	20	254	19	8	F25	1280	5100	58000
20"	914	991	487	545	80	100	71	22	254	19	8	F25	1600	6400	75000
24"	1067	1143	589	640	95	130	86	25	298	23	8	F30	3540	11500	112200
28"	1245	1346	684	715	115	140	104	32	356	33	8	F35	4500	17000	143000

ANSI Class 300 Dimensions

SIZE	A (mm)		D (mm)	E (mm)	F (mm)	H1 (mm)	H2 (mm)	H3 (mm)	J (mm)	K (mm)	n	ISO 5211	Weight (kg)	TORQUE (N.m)	CV
	RF Flanged	Butt Weld													
2"	216	216	49	115	20	35	16.5	6	102	11	4	F10	15	80	470
2 1/2"	241	241	62	128	24	40	20	8	102	11	4	F10	24	120	800
3"	283	283	74	135	24	40	20	8	125	14	4	F12	30	210	1100
4"	305	305	100	180	32	45	24	10	125	14	4	F12	50	260	2200
6"	403	457	150	238	42	60	37	12	165	23	4	F16	106	620	5400
8"	502	521	201	295	48	65	42.5	14	165	23	4	F16	256	1050	10000
10"	568	559	252	328	48	65	42.5	14	165	23	4	F16	330	1850	17100
12"	648	635	303	385	55	70	49	16	254	19	8	F25	440	2350	25000
14"	762	762	335	415	60	75	53	18	254	19	8	F25	770	3300	31000
16"	838	838	385	465	75	95	67.5	20	254	19	8	F25	1030	4800	42000
18"	914	914	436	510	75	95	67.5	20	254	19	8	F25	1542	6800	56000
20"	991	991	487	560	80	100	71	22	254	19	8	F25	2100	8350	72000
24"	1143	1143	589	655	95	130	86	25	298	23	8	F30	4200	15500	102000
28"	1346	1346	684	725	115	140	104	32	356	33	8	F35	5300	23000	123000

Pressure/Temperature Rating for Class 150, 300, 400 & 600

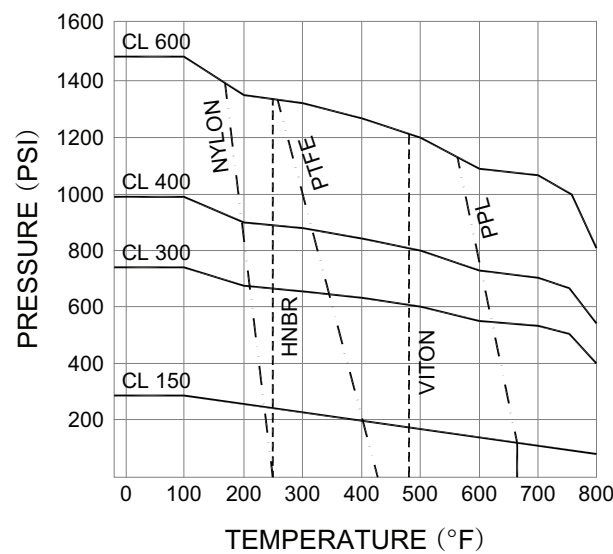

Pressure/Temperature Rating for Class 900 & 1500

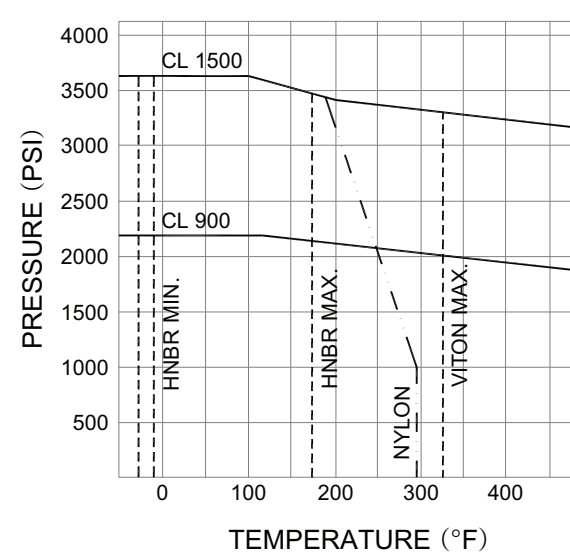

Notes Regarding Pressure/Temperature Graphs

- The above graphs represent just some of the seat/seal combinations available covering typical applications.

Cast Steel Bolted Bonnet Valves



Cast Steel Trunnion Ball Valves • ANSI Class 600~900

ANSI Class 600 Dimensions

SIZE	A (mm)		D (mm)	E (mm)	F (mm)	H1 (mm)	H2 (mm)	H3 (mm)	J (mm)	K (mm)	n	ISO 5211	Weight (kg)	TORQUE (N.m)	CV
	RF Flanged/ Butt Weld	RTJ Flanged													
2"	292	295	49	120	28	40	24	8	102	11	4	F10	24	165	400
2 1/2"	330	333	62	148	32	45	24	10	125	14	4	F12	38	300	700
3"	356	359	74	165	32	45	24	10	125	14	4	F12	50	430	1000
4"	432	435	100	198	38	55	33	10	165	23	4	F16	93	600	1800
6"	559	562	150	268	48	65	42.5	14	165	23	4	F16	202	1550	4500
8"	660	664	201	320	55	75	49	16	254	19	8	F25	357	2470	8900
10"	787	791	252	377	65	75	58	18	254	19	8	F25	666	3850	14500
12"	838	841	303	408	70	90	67.5	20	254	19	8	F25	960	5800	22000
14"	889	892	335	430	75	95	67.5	20	254	19	8	F25	1700	8550	28000
16"	991	994	385	500	85	110	71	22	254	19	8	F25	1970	9400	39000
20"	1194	1200	487	585	95	130	86	25	356	33	8	F35	3250	18500	66000
24"	1397	1407	589	685	115	140	104	32	356	33	8	F35	5800	30500	92000
28"	1549	1562	684	750	135	170	123	36	406	39	8	F40	6700	45000	122000

ANSI Class 900 Dimensions

SIZE	A (mm)		D (mm)	E (mm)	F (mm)	H1 (mm)	H2 (mm)	H3 (mm)	J (mm)	K (mm)	n	ISO 5211	Weight (kg)	TORQUE (N.m)	CV
	RF Flanged/ Butt Weld	RTJ Flanged													
2"	368	371	49	132	28	45	24	8	125	14	4	F12	50	195	360
2 1/2"	419	422	62	165	32	50	24	10	125	14	4	F12	60	380	750
3"	381	384	74	178	32	50	24	10	125	14	4	F12	80	550	1000
4"	457	460	100	205	42	60	37	12	165	23	4	F16	146	950	1800
6"	610	613	150	280	48	65	42.5	14	165	23	4	F16	270	2150	4300
8"	737	740	201	338	60	75	53	18	254	19	8	F25	605	3500	8400
10"	838	841	252	392	70	90	67.5	20	254	19	8	F25	740	7100	14000
12"	965	968	303	425	80	100	71	22	298	23	8	F30	1050	9620	21000
14"	1029	1038	322	465	95	130	86	25	298	23	8	F30	1400	16000	26000
16"	1130	1140	373	520	100	130	90	28	356	33	8	F35	2050	20000	36000
18"	1219	1232	424	570	115	140	104	32	356	33	8	F35	3000	25000	47500
20"	1321	1334	471	602	115	140	104	32	356	33	8	F35	4200	36200	60000
24"	1549	1569	570	705	135	170	123	36	406	39	8	F40	5900	48500	86000



Cast Steel Bolted Bonnet Valves

Cast Steel Trunnion Ball Valves • ANSI Class 1500

ANSI Class 1500 Dimensions

SIZE	A (mm)		D (mm)	E (mm)	F (mm)	H1 (mm)	H2 (mm)	H3 (mm)	J (mm)	K (mm)	n	ISO 5211	Weight (kg)	TORQUE (N.m)	CV
	RF Flanged/ Butt Weld	RTJ Flanged													
2"	368	371	49	170	30	45	26	8	125	14	4	F12	50	350	360
2 1/2"	419	422	62	190	32	50	24	10	140	19	4	F14	75	640	690
3"	470	473	74	215	38	55	33	10	165	23	4	F16	117	950	900
4"	546	549	100	240	48	65	42.5	14	165	23	4	F16	216	1700	1600
6"	705	711	144	300	60	75	53	18	254	19	8	F25	380	3650	4000
8"	832	841	192	350	75	95	67.5	20	254	19	8	F25	680	7450	7900
10"	991	1000	239	395	85	110	71	22	298	23	8	F30	840	11500	13000
12"	1130	1146	287	445	95	130	86	25	298	23	8	F30	1150	16500	19000
14"	1257	1276	316	470	100	130	90	28	356	33	8	F35	1550	24000	24000
16"	1384	1407	360	545	120	160	109	32	356	33	8	F35	2200	34500	33000

HOW TO ORDER

2"	Flanged Ball Valve	CF8	304SS	PTFE	Graphoil	150	Air-operated
Size	Series	Body & End Material	Ball & Stem Material	Seat Material	Seal Material	End Style	Options
2"	Flanged Ball Valve	Carbon Steel	ASTM A105	PTFE	Graphoil	150 - Class150Lb	Gear Operated
2 1/2"	Butt Welding Ball Valve	ASTM A351 CF8M	316 SS	Nylon	PTFE	300 - Class300Lb	Lever Handle
3"		ASTM A351 CF8	304 SS	PEEK		600 - Class600Lb	Air-operated
4"		ASTM A352 LCB	316L	Devlon		900 - Class900Lb	
6"		ASTM A351 CF3	304L	Metal		1500 - Class1500Lb	
8"		ASTM A351 CF3M					
10"							
12"							
14"							
16"							
18"							
20"							
24"							
28"							

* This brochure is general in nature and we reserve the right to alter dimensions, materials or make design improvements.